

Sport Exhaust System (OP8/OP9)

Vehicle Type: **Macan S (95B)**

Model Year: **As of 2019**

Engine Type: **DLZ/DLZB = V6/3.0 liter/260 kW (354 hp)**

Restriction: **ONLY** approved for vehicles produced from week 2/2019!

Concern: **Retrofitting**



Figure 1

Notes: In the sport exhaust system, the signal for activating the flaps in the rear mufflers comes from the respective current map in the DME control unit. This depends on the driving status and the accelerator pedal position among other things.

The sport exhaust system can be activated and deactivated separately using the new "Twin tailpipe" button (on switch panel in center console ⇒ Figure 1) or the standard "Sport" button. The sport exhaust system is also active in "Sport Plus" mode on vehicles with Sport Chrono Package.

Engine power and exhaust behavior of the vehicle are not affected.

The sport exhaust system is also available as a factory installed option for new vehicles by requesting optional equipment "OP8 – Sport exhaust system (Brushed stainless steel tailpipe)" or "OP9 – Sport exhaust system (Black chrome-plated look tailpipe)".

Parts Info: **95B.044.211** ⇒ Sport exhaust system – Tailpipe in Silver chrome-plated look, set
95B.044.211.A ⇒ Sport exhaust system – Tailpipe in Black chrome-plated look, set

Also order the required button module (⇒ *Figure 2*) depending on vehicle equipment:



Figure 2

95B.907.042.BL	1 x	Button module (7Y2/7Y3 + OP8/OP9) ⇒ <i>Figure 2-1-</i> Standard: 95B.907.042.BJ
95B.907.042.BM	1 x	Button module (7Y2/7Y3 + OP8/OP9 + 7L4/7L8) ⇒ <i>Figure 2-2-</i> Standard: 95B.907.042.BK
95B.907.042.BC	1 x	Button module (7Y2/7Y3 + OP8/OP9 + 2V4) ⇒ <i>Figure 2-3-</i> Standard: 95B.907.042.BA
95B.907.042.BD	1 x	Button module (7Y2/7Y3 + OP8/OP9 + 7L4/7L8 + 2V4) ⇒ <i>Figure 2-4-</i> Standard: 95B.907.042.BB
95B.907.042.BR	1 x	Button module (7Y6/7Y7 + OP8/OP9) ⇒ <i>Figure 2-5-</i> Standard: 95B.907.042.BN
95B.907.042.BS	1 x	Button module (7Y6/7Y7 + OP8/OP9 + 7L4/7L8) ⇒ <i>Figure 2-6-</i> Standard: 95B.907.042.BQ

95B.907.042.BG	1 x	Button module (7Y6/7Y7 + OP8/OP9 + 2V4) ⇒ <i>Figure 2-7-Standard: 95B.907.042.BE</i>
95B.907.042.BH	1 x	Button module (7Y6/7Y7 + OP8/OP9 + 7L4/7L8 + 2V4) ⇒ <i>Figure 2-8-Standard: 95B.907.042.BF</i>

Parts list:

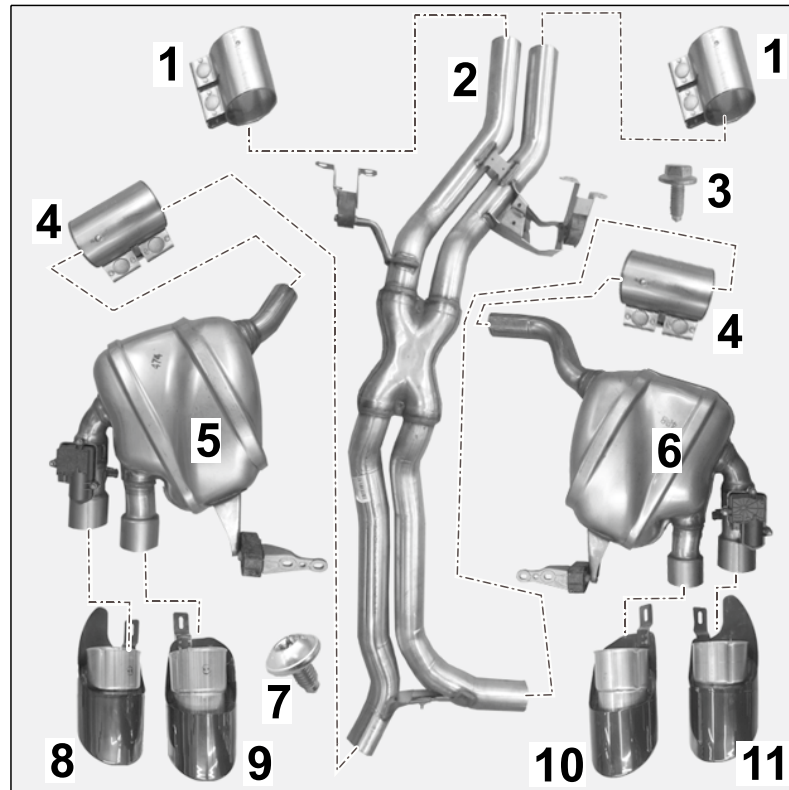

Figure 3

Parts included for exhaust system (⇒ *Figure 3*):

958.111.220.10	2 x	Clamping sleeve, Ø 65 x 88 ⇒ <i>Figure 3-1-</i>
95B.253.487.MY	1 x	Exhaust pipe assembly ⇒ <i>Figure 3-2-</i>
N.023.003.16	4 x	Hexagon nut, M8 (not shown)
N .019.530.7	2 x	Hexagon flange bolt, M8 x 25 (exhaust system) ⇒ <i>Figure 3-3-</i>
958.111.220.10	2 x	Clamping sleeve, Ø 65 x 88 ⇒ <i>Figure 3-4-</i>
N .106.620.01	6 x	Hexagon flange bolt, M8 x 40 (exhaust system, not shown)
95B.253.611.MY	1 x	Rear muffler assembly – left ⇒ <i>Figure 3-5-</i>
95B.253.612.MY	1 x	Rear muffler assembly – right ⇒ <i>Figure 3-6-</i>
999.073.594.01	4 x	Countersunk screw, M6 x 12 PA ⇒ <i>Figure 3-7-</i>
95B.253.681.R ¹	1 x	Sport tailpipe, black chrome-plated, outer left ⇒ <i>Figure 3-8-</i>

95B.253.681.Q ¹	1 x	Sport tailpipe, black chrome-plated, inner left ⇒ <i>Figure 3-9-</i>
95B.253.682.Q ¹	1 x	Sport tailpipe, black chrome-plated, inner right ⇒ <i>Figure 3-10-</i>
95B.253.682.R ¹	1 x	Sport tailpipe, black chrome-plated, outer right ⇒ <i>Figure 3-11-</i>
95B.253.681.P ¹	1 x	Sport tailpipe, silver chrome-plated, outer left (not shown)
95B.253.681.N ¹	1 x	Sport tailpipe, silver chrome-plated, inner left (not shown)
95B.253.682.N ¹	1 x	Sport tailpipe, silver chrome-plated, inner right (not shown)
95B.253.682.P ¹	1 x	Sport tailpipe, silver chrome-plated, outer right (not shown)

¹ **ONLY** contained in respective set!



Figure 4

Parts included for electrical system (⇒ *Figure 4*):

95B.907.159.E	1 x	Engine noise control unit ⇒ <i>Figure 4-1-</i>
999.076.081.40	2 x	Hexagon nut, M6, plastic ⇒ <i>Figure 4-2-</i>
4H0.907.601.D	1 x	Engine noise pulse sender ⇒ <i>Figure 4-3-</i>
N.908.877.03	1 x	M6 hexagon nut, self-locking ⇒ <i>Figure 4-4-</i>
95B.044.200.25	1 x	Wire harness for engine noise control unit/pulse sender including adapter cable (secured) ⇒ <i>Figure 4-5-</i>

95B.044.213	1 x	Wire harness for connection point/exhaust flap – left-hand drive vehicle ⇒ <i>Figure 4 -6-</i>
N .912.098.01	1 x	Screw, self-locking (belt fitting) ⇒ <i>Figure 4 -7-</i>
999.513.052.40	25 x	Tie-wrap, 4.8 x 188 (not shown)



Information

ONLY in the event of repairs/replacement:

Items **WITHOUT** a part number in the parts list can be found/ordered from the Porsche Electronic Parts Catalog = PET.

Check model year and vehicle equipment (I-no.) in the standard catalog!

Materials:	000.043.172.00	1 x	Sealing cord
	— — —	1 x	Commercially available rust solvent, e.g. WD40
	— — —	1 x	Wrapping tape (commercially available)
	— — —	1 x	Auxiliary line (Tekalan or Teflon hose) approx. 1,500 mm long

Tools:	VAS 6935 - Pole terminal puller	Nr.90 Pos.1 - Torque wrench
	9873 - Hood stay	3438 - Hook
	9900 - PIWIS Tester 3	VAS 6931 - Transmission and Engine Jack
	Restraining strap for securing loads	Shop light
	Three-mandrel pliers for hoses and sleeves (commercially available)	

Work Procedure: 1 Preparatory work

- 1.1 Drive the vehicle onto the lifting platform (⇒ *Workshop Manual '4X00IN Lifting the vehicle*).
- 1.2 Connect battery charger (⇒ *Workshop Manual '2X00IN Battery trickle charging*).
- 1.3 Work in the exhaust system area

- 1.3.1 Remove tunnel cover on –center–underbody (⇒ *Figure 6*, ⇒ *Workshop Manual '519319 Removing and installing cover for centre underbody*).

- 1 – Tunnel cover on –center–underbody
- 2 – Exhaust system

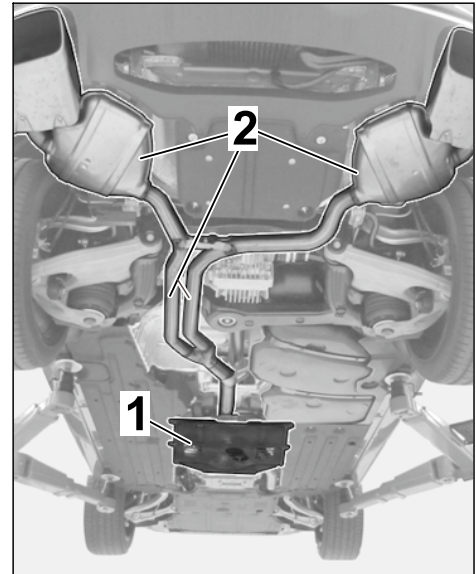

Figure 6

- 1.3.2 Secure catalytic converter exhaust pipes on the transmission support (⇒ *Figure 7 (4-cylinder)*) using restraining strap for securing loads, for example, to prevent them from bending down.

- 1 – Restraining strap for securing loads
- 2 – Transmission support
- 3 – Clamping sleeve, Ø 65 x 88

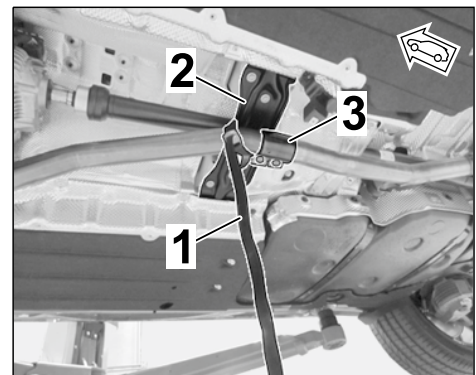

Figure 7 (4-cylinder)

- 1.3.3 **VAS 6931 - Engine and gearbox jack** must be positioned under the exhaust system (in transfer case area). Then, secure the exhaust system with restraining straps to prevent it from falling down (⇒ *Figure 8*).

- 1 – Transmission and Engine Jack
- 2 – Exhaust system
- 3 – Transfer case on rear axle

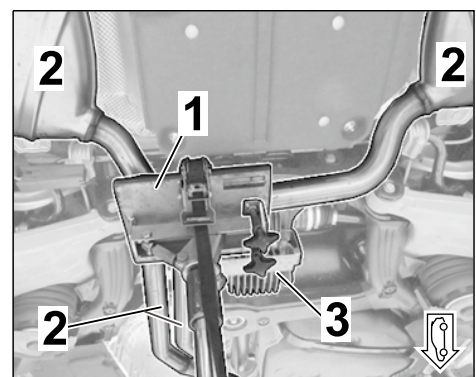

Figure 8

⚠ CAUTION

Hot components

- Risk of burns
- ⇒ Let hot components cool down.
- ⇒ Wear personal protective gear.

⚠ CAUTION

Heavy components

- Risk of pinching
- ⇒ Wear personal protective gear.
- ⇒ Get someone to help if necessary.



Information

The help of another person is required for this step.

1.3.4 Remove exhaust system including front/rear mufflers and tailpipes (⇒ *Workshop Manual '260119 Removing and installing exhaust system (V6 Turbo)*).

1.3.5 Detach heat shield in the rear muffler area – at the left (⇒ *Figure 9*) and bend it down slightly.

- 1 – Cap nut
- 2 – Heat shield
- 3 – Dummy plug
- 4 – Filler

1.3.6 Remove dummy plug on underbody and de-burr using a spatula (⇒ *Figure 9 -inset-*).

1.4 Expose the plenum panel area

1.4.1 Move front lid into service position (⇒ *Workshop Manual '552213 Securing front lid (service position)*).

1.4.2 Remove wiper arms (⇒ *Workshop Manual '922519 Removing and installing wiper arm*)

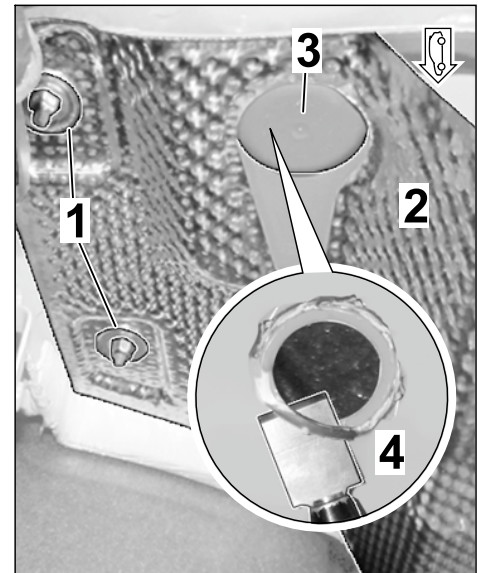

Figure 9

1.4.3 Remove cowl panel cover (⇒ *Workshop Manual '508719 Removing and installing cowl panel cover'*)

1.4.4 Remove cover on fuse box (E-box) in cowl panel (⇒ *Figure 10* , ⇒ *Workshop Manual '978409 Loosening and securing fuse box'*)

- 1 – Fuse box (E-box) in cowl panel
- 2 – Foam pads on bulkhead

1.4.5 Remove foam pads on bulkhead (⇒ *Figure 10-2-*).

1.5 Expose A-pillar area (on driver's side)

1.5.1 Remove dashboard trim panel (⇒ *Figure 11-1-*) (⇒ *Workshop Manual '701619 Removing and installing dashboard trim panel'*)

- 1 – Dashboard trim panel
- 2 – Air vent (instrument cluster)
- 3 – Trim panel under dashboard

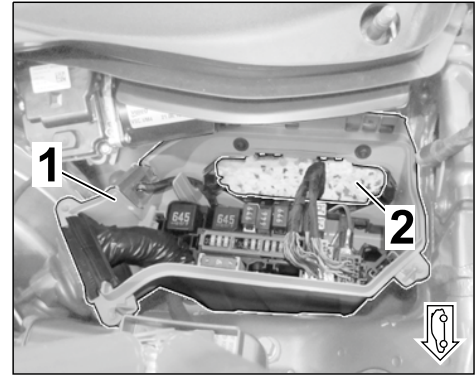

Figure 10

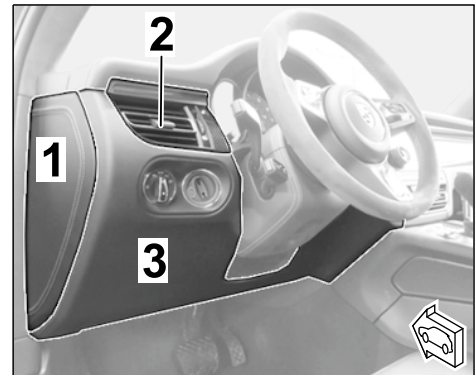

Figure 11

1.5.2 Remove air vent (on instrument cluster ⇒ *Figure 11-2-* / ⇒ *Figure 12-1-*) and air vent unit (underneath the PCM ⇒ *Figure 12-3-*).

- 1 – Air vent (instrument cluster)
- 2 – Dashboard moulding (right)
- 3 – Air vent unit (PCM)
- 4 – Trim panel under dashboard

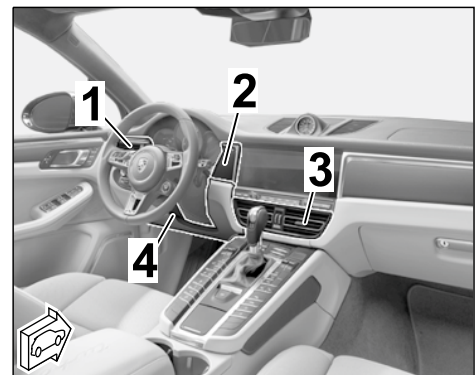

Figure 12

1.5.3 Remove dashboard moulding/trim panel (at the right ⇒ *Figure 12-2-*) (⇒ *Workshop Manual '70581902 Removing and installing dashboard moulding on driver's side (right)'*)

1.5.4 Remove trim panel under dashboard (⇒ Figure 13) (⇒ Workshop Manual '701919 Removing and installing trim panel under dashboard on driver's side').

- 1 – Trim panel under dashboard
- 2 – Dashboard

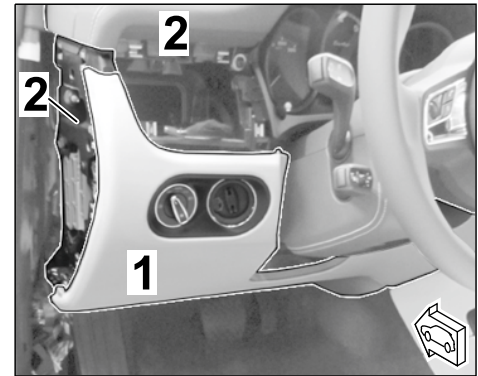

Figure 13

1.5.5 Remove front inner door sill trim (⇒ Figure 14) (⇒ Workshop Manual '680519 Removing and installing front inner door sill trim').

- 1 – Front lid release
- 2 – Front inner door sill trim (on driver's side)

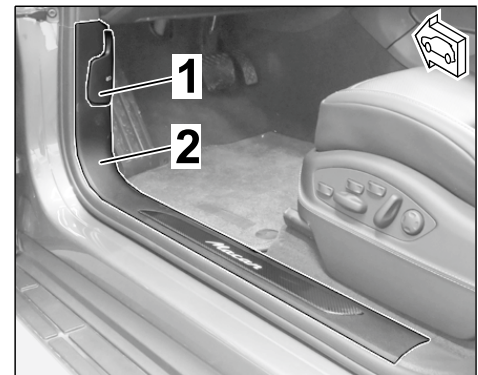

Figure 14

1.6 Expose B-pillar area (on driver's side)

1.6.1 Remove luggage compartment cover and empty the luggage compartment.

1.6.2 Detach/remove rear backrest (⇒ Figure 15-1-, ⇒ Workshop Manual '724719 Removing and installing rear backrest').

- 1 – Rear backrest
- 2 – Rear seat
- 3 – Upper part of B-pillar trim panel (on driver's side)
- 4 – Lower part of B-pillar trim panel (on driver's side)

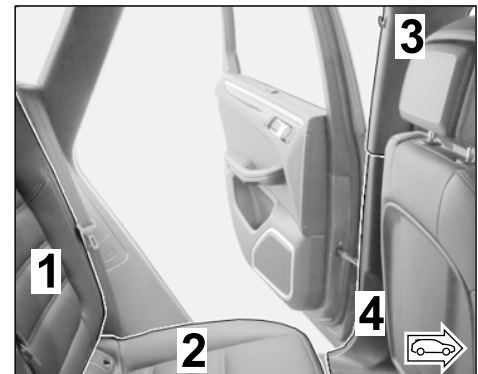

Figure 15

1.6.3 Remove rear seat (⇒ Figure 15-2-, ⇒ Workshop Manual '724819 Removing and installing rear seat').

1.6.4 Remove upper part of B-pillar trim panel (on driver's side ⇒ Figure 15-3-, ⇒ Workshop Manual '706719 Removing and installing upper part of B-pillar trim panel').

- 1.6.5 Remove lower part of B-pillar trim panel (on driver's side ⇒ *Figure 15-4-*, ⇒ *Workshop Manual '70671903 Removing and installing lower part of B-pillar trim panel*).
- 1.7 Expose C-pillar/luggage compartment area
- 1.7.1 Remove side trim panel for rear luggage compartment (at the left) (⇒ *Workshop Manual '700319 Removing and installing side trim panel for rear luggage compartment*).
- 1.7.2 Remove side trim panel for luggage compartment (loadspace cover) (at the left) (⇒ *Workshop Manual '700619 Removing and installing trim panel for luggage compartment (luggage compartment cover) at the sides*).
- 1.7.3 **ONLY** for vehicles with spare wheel (space-saving – 1G1/1G4):
Remove compressor tool kit (⇒ *Figure 16*).
- 1 – Compressor tool kit
2 – Clamping washer, 5 x 30
- 1.7.4 Remove rear inner door sill trim (on driver's side) (⇒ *Workshop Manual '680519 Removing and installing rear inner door sill trim*).

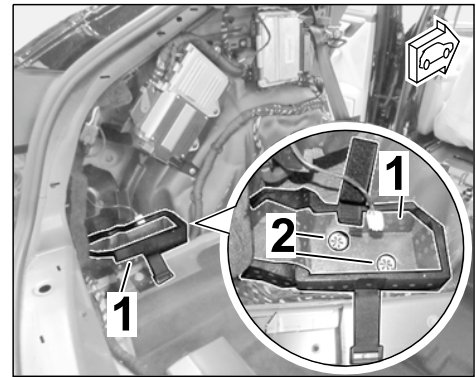

Figure 16

- 2 Install engine noise control unit and pulse sender
- 2.1 Release secured adapter cable with plug connection (3-pin) and bag of small parts from electric wire harness for engine noise control unit/pulse sender (⇒ *Figure 17*).
- 1 – Wire harness for engine noise control unit/pulse sender including adapter cable
2 – Adapter cable with plug connection (3-pin)
3 – Bag of small parts
- 2.2 Fit engine noise control unit (⇒ *Figure 18*)
- 2.2.1 Connect plug connection for wire harness for engine noise control unit/pulse sender to the engine noise control unit (6-pin).

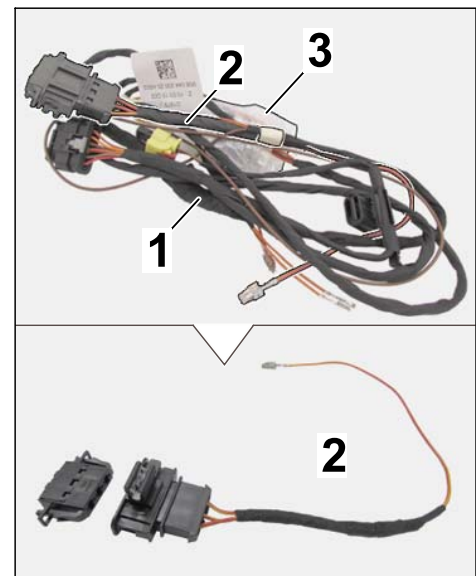

Figure 17

2.2.2 Position engine noise control unit on M6 studs (2 x) in the plenum panel and secure with two M6 hexagon nuts (\Rightarrow Figure 18).

- 1 - Engine noise control unit
- 2 - Wire harness for engine noise control unit/pulse sender
- 3 - Hexagon nut, M6

Tightening torque 5 Nm (3.5 ftlb.) \pm 0.75 Nm (\pm 0.4 ftlb.)

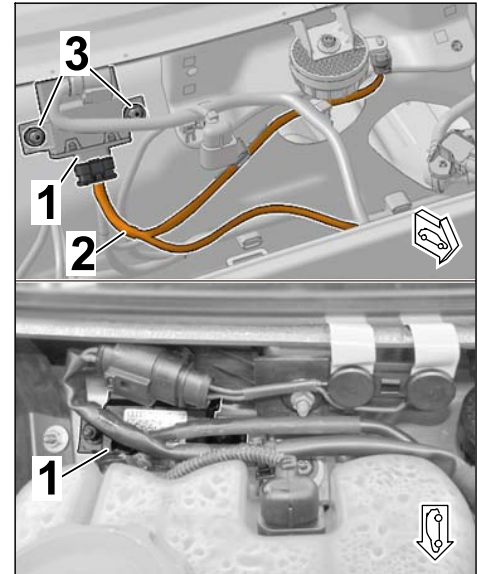

Figure 18

NOTICE

Incorrect line routing

- Risk of damage to lines and hoses
 - Malfunction and fault memory entry on control unit
- \Rightarrow Avoid small bending radii when routing lines.
- \Rightarrow File down edges and burrs in the routing area or mask them with adhesive tape.
- \Rightarrow Maintain a sufficient distance from components exposed to high temperatures while driving.

2.3 Fit engine noise pulse sender (\Rightarrow Figure 19)



Information

Check that the electric line for the plug connection for the engine noise pulse sender is routed correctly.

- The line must **NOT** be touching the engine noise pulse sender holder (on the body side)!

- Route the line differently if necessary and use a tie-wrap to secure the line to existing lines or holders without tensile stress and so that no chafing or rattling occurs.

2.3.1 Route branch with connector (2-pin) to the engine noise pulse sender holder (\Rightarrow *Figure 19-top*).

- 1 – Branch with connector (2-pin)
- 2 – Engine noise pulse sender
- 3 – Hexagon nut, M6
- 4 – Cable clip

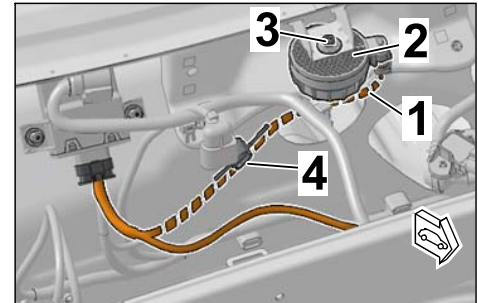

2.3.2 Connect plug connection for wire harness for engine noise control unit/pulse sender to the engine noise pulse sender (2-pin).

2.3.3 Guide pin on underside of engine noise pulse sender into the bore on the holder in the plenum panel.

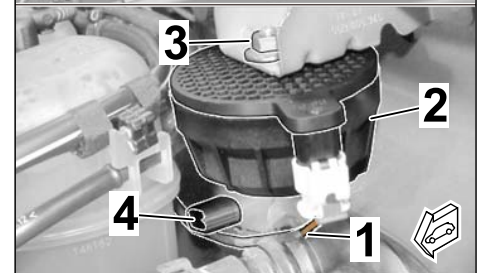

Figure 19

Secure engine noise pulse sender, facing downwards, in the plenum panel holder using M6 hexagon nut (1 x) (\Rightarrow *Figure 19*)

Tightening torque 5 Nm (3.5 ftlb.) +/- 0.75 Nm (+/- 0.4 ftlb.)

2.3.4 Fit cable clip on bulkhead stud (\Rightarrow *Figure 19-4*).

2.4 Route electric wire harness for engine noise control unit/pulse sender

Wire harness connections – left-hand drive vehicles (\Rightarrow *Figure 20*, right-hand drive vehicles = mirror image)

- 1 – Engine noise control unit connector (6-pin)
- 2 – Engine noise pulse sender connector (2-pin)
- 3 – Line clip
- 4 – Socket contacts for CAN lines \Rightarrow connector (17-pin, white)
- 5 – Pin contacts for CAN lines \Rightarrow plug socket (2-pin)
- 6 – Socket contact for terminal 15 \Rightarrow plug socket (3-pin, adapter cable)
- 7 – Cable ring eyelet A6 \Rightarrow ground pin on A-pillar

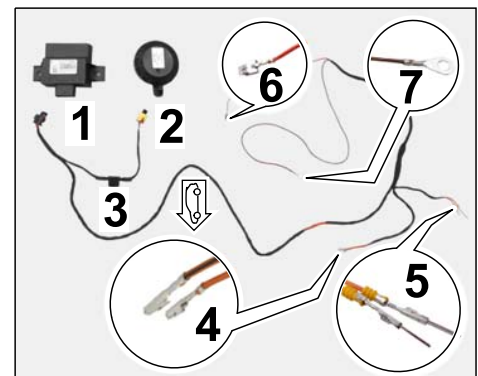

Figure 20

2.4.1 Carefully secure all contacts (⇒ *Figure 20-4 to 7-*) to the wire harness for engine noise control unit/pulse sender using wrapping tape.

2.4.2 Route wire harness to the fuse box (E-box) in the cowl panel as follows:

- 1 – Engine noise control unit
- 2 – Engine noise pulse sender
- 3 – Coolant reservoir
- 4 – Brake booster
- 5 – Sleeve on fuse box (E-box)

- **LHD vehicles:** (⇒ *Figure 21*)
 Engine noise control unit/pulse sender → underneath coolant reservoir → underneath brake booster → sleeve on fuse box (E-box) in cowl panel (left side)

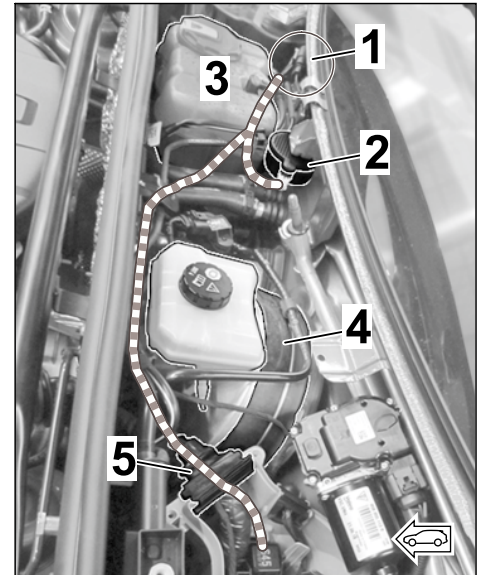

Figure 21

2.4.3 Secure wire harness for engine noise control unit/pulse sender to existing lines/components with tie-wraps without tensile stress and so that no chafing occurs.

2.4.4 Remove sleeve from fuse box (E-box) in cowl panel and cut off pre-shaped cone (repair opening) (⇒ *Figure 22*).

- 1 – Sleeve
- 2 – Fuse box (E-box)

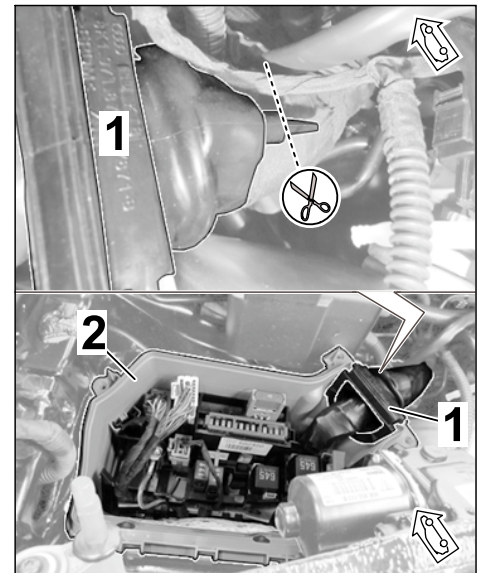

Figure 22

**Information**

Use three-mandrel pliers for hoses and sleeves (commercially available) if necessary.

- 2.4.5 Carefully guide wire harness for engine noise control unit/pulse sender through the new opening (sleeve) into the fuse box (E-box) (⇒ *Figure 23*).

- 1 – Wire harness for engine noise control unit/pulse sender
- 2 – Sleeve (fuse box – E-box)
- 3 – Branch for CAN lines
- 4 – Branch for power supply/ground
- 5 – Opening on bulkhead

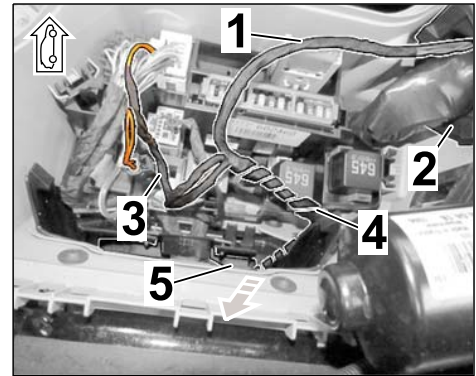

Figure 23

- 2.4.6 Seal wire harness in the sleeve using inner/outer sealing cord and fit sleeve in the fuse box in the cowl panel.

- 2.4.7 Route branch for power supply/ground (line BN; 1.0² with cable ring eyelet and line RD/YE; 1.0²) from wire harness for engine noise control unit/pulse sender) to the passenger compartment as follows (⇒ *Figure 24*):

- 1 – Branch for power supply/ground
 - 2 – Ground pin 21 (left-hand drive)
 - 3 – Fuse strip A
- Fuse box (E-box) in cowl panel
→ above fuses/relays →
through opening on bulkhead
→ fuse/relay carrier on A-pillar
(on driver's side)

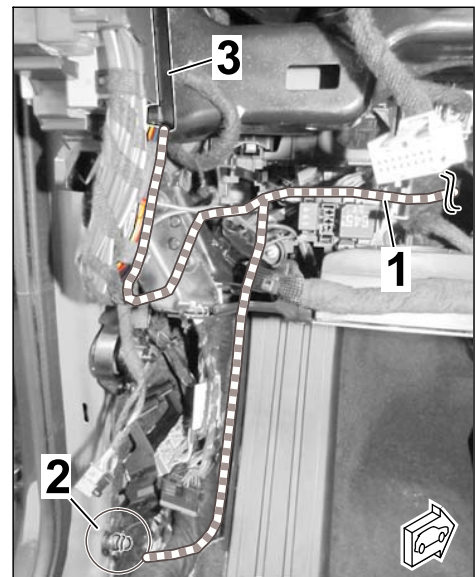

Figure 24

- 2.5 Connect CAN lines of electric wire harness for engine noise control unit/pulse sender

- 2.5.1 Take connector housing and plug socket (2-pin) for CAN lines out of the bag of small parts.

Insert a small screwdriver between the pin connector socket and connector housing (⇒ *Figure 25 -a-*).

- 1 - Pin connector socket (2-pin)
- 2 - Connector housing (2-pin)

Carefully lift up connector housing (⇒ *Figure 25 -b-*) and pull out pin connector socket.



Information

CAN lines must be twisted properly!

Manually re-twist untwisted lines at plug connections/splice greater than 50 mm.

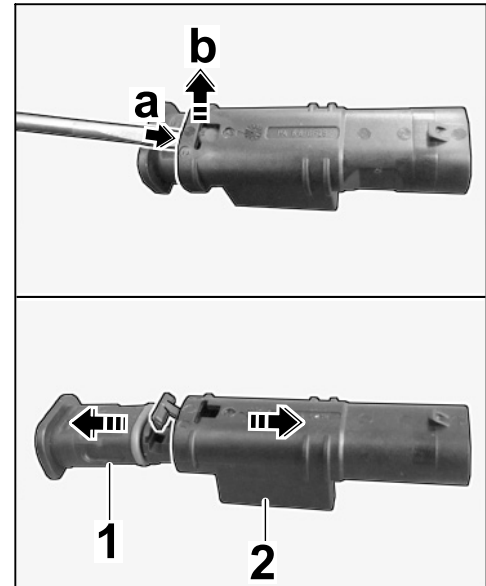

Figure 25



Information

Observe markings on the housing!

2.5.2 Connect CAN lines with pin contact/single-wire seal (wire harness for engine noise control unit/pulse sender) in the pin connector socket as follows (⇒ *Figure 26*):

- 1 - OG/BN line ⇒ chamber 1 (pin connector socket)
- 2 - OG/BK line ⇒ chamber 2 (pin connector socket)
- 3 - Connector (2-pin)

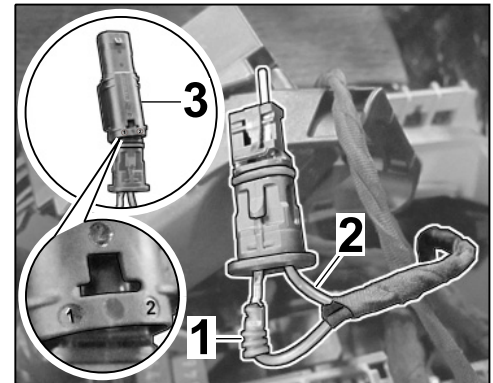

Figure 26

Function/line:	Pin connector socket (2-pin)
Control CAN drive LOW = OG/BN; 0.35 ²	⇒ insert into chamber 1 of pin connector socket (2-pin)
Control CAN drive HIGH = OG/BK; 0.35 ²	⇒ insert into chamber 2 of pin connector socket (2-pin)

Fit pin connector socket (2-pin) back into the connector housing.

- 2.5.3 Release (2-pin) plug socket
(⇒ *Figure 27*).

- 1** – Plug socket (2-pin)
2 – Secondary lock

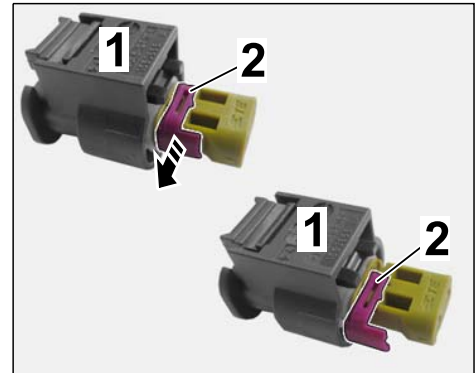

Figure 27

- 2.5.4 Remove and release connector
(17-pin, white) from fuse/relay carrier
(E-box, connection point
X372.1A1) (⇒ *Figure 28*).

- 1** – Connector (17-pin, white)
2 – Fuse/relay carrier (E-box)
3 – Secondary lock

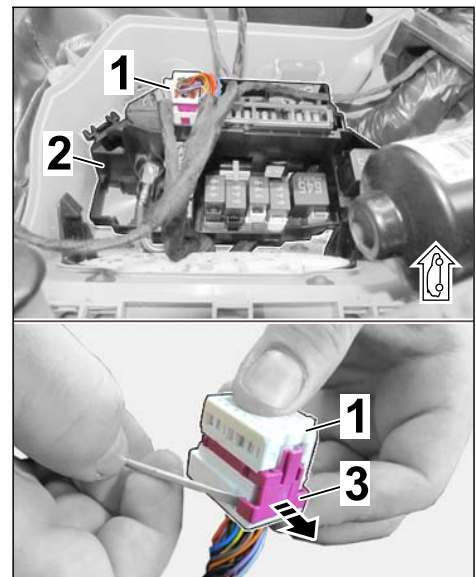

Figure 28

2.5.5 Change pin assignment of lines OG/BN / OG/BK in the connector (17-pin, white) as follows (⇒ *Figure 29*):

- 1 - Connector (2-pin)
- 2 - Socket (2-pin)
- 3 - Connector (17-pin, white)
- 4 - Wire harness for engine noise control unit/pulse sender
- 5 - Vehicle wire harness

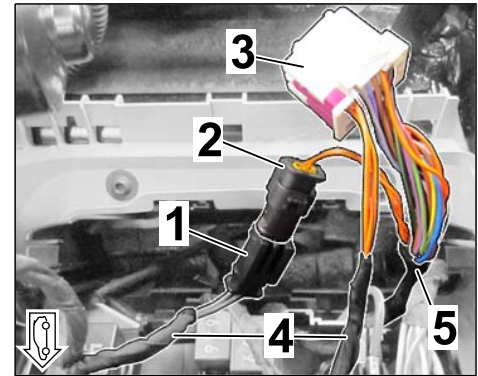

Figure 29

Function/line:	Connector (17-pin, white)
Control CAN drive LOW = OG/BN; 0.35 ²	Unpin socket from chamber 13 ⇒ insert into chamber 1 of plug socket (2-pin ⇒ <i>Figure 27</i>)
Control CAN drive HIGH = OG/BU; 0.35 ²	Unpin socket from chamber 14 ⇒ insert into chamber 2 of plug socket (2-pin ⇒ <i>Figure 27</i>)

Lock the plug socket (black, 2-pin) (⇒ *Figure 27*).

2.5.6 Insert socket for lines OG/BN / OG/BK (wire harness for engine noise control unit/pulse sender) into the connector (white, 17-pin) as follows:

Function/line:	Wire harness (engine noise control unit/pulse sender)
Control CAN drive LOW = OG/BN; 0.35 ²	Socket ⇒ insert into chamber 13 of connector (17-pin, white ⇒ <i>Figure 29-3-</i>)
Control CAN drive HIGH = OG/BU; 0.35 ²	Socket ⇒ insert into chamber 14 of connector (17-pin, white ⇒ <i>Figure 29-3-</i>)

Lock the connector (17-pin, white) and fit it in the fuse box (connection point X372.1A1).

2.5.7 Connect plug connection (2-pin) (⇒ *Figure 29-1 & 2-*).

2.6 Connect adapter cable with connector (3-pin) to terminal 15 and fit it

- 2.6.1 Disconnect plug connection (3-pin) of adapter cable and release/open plug socket (3-pin) (\Rightarrow *Figure 30*).

- 1 – Adapter cable with connector (3-pin)
- 2 – Plug socket (3-pin)
- 3 – Line RD/YE; 1.0² with socket \Rightarrow fuse strip A, chamber 3A

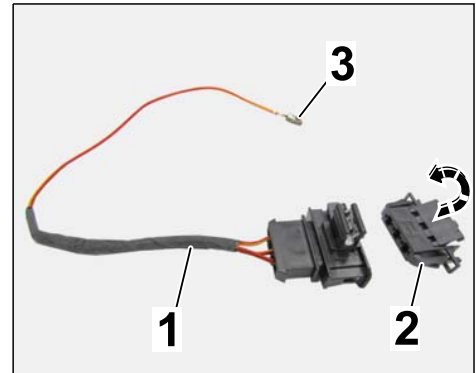

Figure 30

- 2.6.2 Release fuse strip A (black) using a screwdriver and remove it by pulling it to the rear and out of the fuse carrier (A-pillar area) (\Rightarrow *Figure 31*).

- 1 – Fuse strip A (black)
- 2 – Cover

Release cover (\Rightarrow *Figure 31 -2-*) on fuse strip A (black) at both sides and remove it.

Open secondary lock on fuse strip A (black) (\Rightarrow *Figure 31 -B-*).

- 2.6.3 Remove wrapping tape from standard wire harness (\Rightarrow *Figure 31 -3-*).

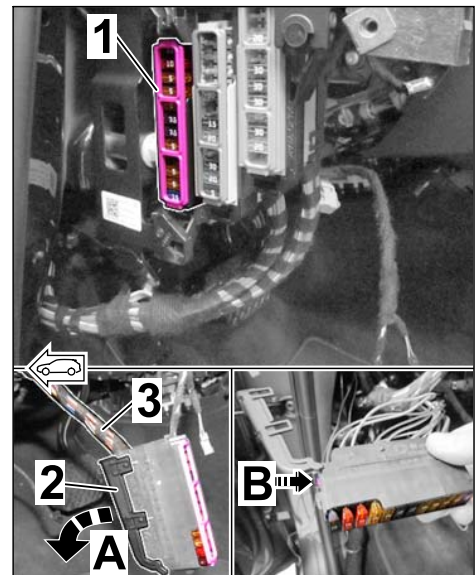

Figure 31

2.6.4 Assign plug socket (3-pin) as follows (⇒ *Figure 32*):

- 1 – Line RD/YE; 1.0² (in vehicle)
- 2 – Fuse strip A
- 3 – Line RD/YE; 1.0² (wire harness for engine noise control unit/pulse sender)
- 4 – Plug socket (3-pin)
- 5 – Pin connector socket (3-pin)

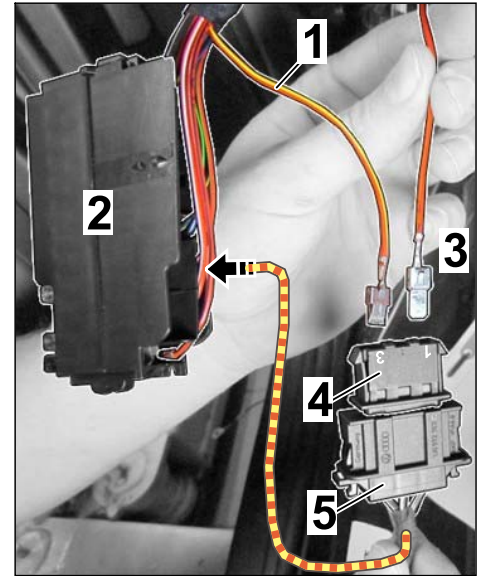

Figure 32

Function/line:	Plug socket (3-pin)
Terminal 15 RD/YE; 1.0 ²	Unpin line (in the vehicle ⇒ <i>Figure 32-1-</i>) with socket out of fuse strip A, chamber 3A ⇒ insert into chamber 1 of plug socket (3-pin)
Terminal 15 RD/YE; 1.0 ²	Line (wire harness for engine noise control unit/pulse sender ⇒ <i>Figure 32-3-</i>) ⇒ insert into chamber 3 of plug socket (3-pin)

2.6.5 Lock plug socket (3-pin) and wind wrapping tape around both lines RD/YE; 1.0².

2.6.6 Insert line RD/YE; 1.0² with socket from pin connector socket (black, 3-pin) into fuse strip A, chamber 3A.

2.6.7 Close secondary lock on fuse strip A (black).

Fit cover on fuse strip A (black) and fit fuse strip A (black) in the fuse carrier (A-pillar area).

2.6.8 Fit pin connector socket (3-pin) with clip onto the dashboard bracket and connect plug connection (3-pin) (⇒ *Figure 33*).

- 1 – Connector (3-pin)
- 2 – Dashboard bracket

2.6.9 Secure adapter cable to existing lines/components with tie-wraps without tension and so that no chafing occurs.

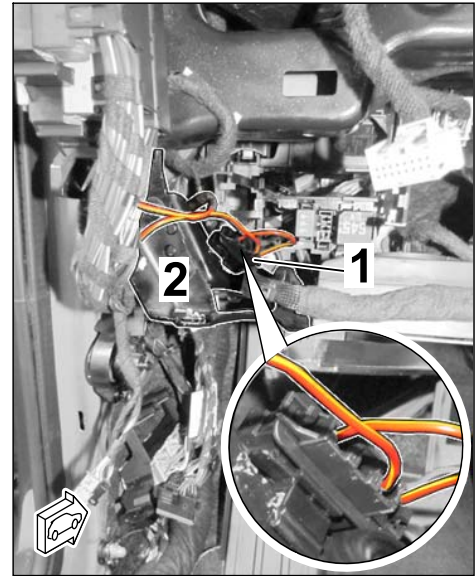

Figure 33

2.7 Route line BN; 1.0² with cable shoe (ground) to the ground pin MB 21 (left-hand drive)/MB 22 (right-hand drive) and fit it (⇒ *Figure 34*).

- 1 – Line BN 1.0² with cable shoe (ground)
- 2 – Ground pin 21 (left-hand drive)

Tightening torque 9 Nm (6.5 ftlb.)

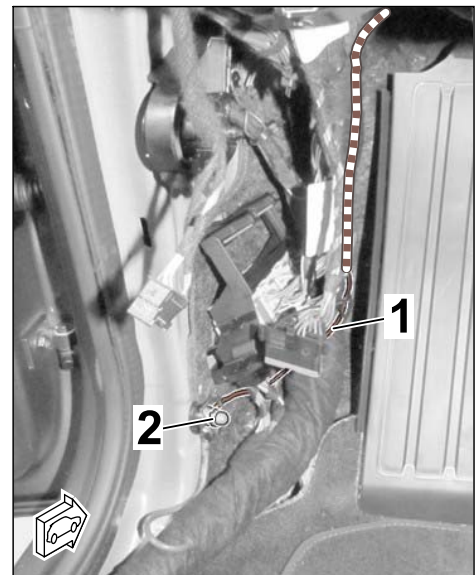

Figure 34

- 3 Route and connect wire harness for connection point/exhaust flap
 - 1 – Pin connector socket (2-pin) with socket contact ⇒ connector (17-pin, red)
 - 2 – Cable ring eyelet A6 ⇒ ground pin 43
 - 3 – Connector (4-pin) ⇒ exhaust flap on rear muffler (left)
 - 4 – Plug socket (2-pin) ⇒ pin connector socket (2-pin)
 - 5 – Socket contact, line VT/BU; 0.5² ⇒ connector (17-pin, red)
 - 6 – Socket contact, line BU/BT; 0.5² ⇒ connector (17-pin, red)

– Wire harness connections (⇒ Figure 35):

- 3.1 Fit ground line BN; 0.5² with cable ring eyelet A6

- 3.1.1 **ONLY** for vehicles with Burmester® High-End Surround Sound System (9VJ):
Disconnect loudspeaker booster and swivel it aside (⇒ *Workshop Manual '914419 Removing and installing loudspeaker booster'*).

- 1 – Loudspeaker booster
- 2 – Ground pin 43
- 3 – Line BN; 0.5²

- 3.1.2 Route branch of line BN; 1.0² with cable ring eyelet A6 (ground) above the (left) wheel housing to the ground pin MB 43.

- 3.1.3 Fit cable ring eyelet A6 (ground) on ground pin MB 43 (⇒ Figure 36)

Tightening torque 9 Nm (6.5 ftlb.)

- 3.1.4 **ONLY** for vehicles with Burmester® High-End Surround Sound System (9VJ):
Fit loudspeaker booster (⇒ *Workshop Manual '914419 Removing and installing loudspeaker booster'*).

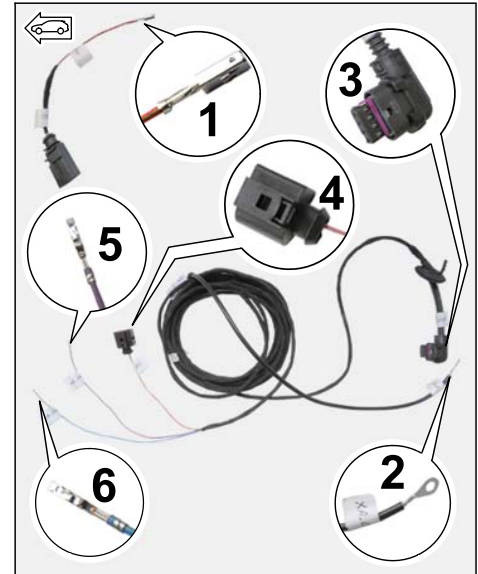

Figure 35

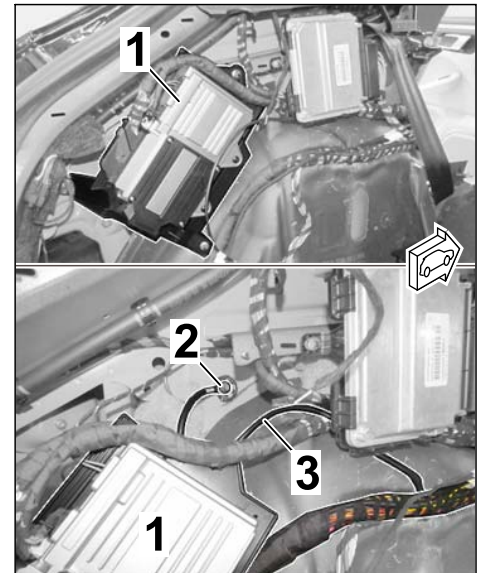

Figure 36

3.2 Route branch for exhaust flap (left) as follows:

- 1 – Ground pin 43
- 2 – Wheel housing liner (left)
- 3 – Rear closing panel
- 4 – Branch for exhaust flap (left)
- 5 – Branch for connection point

- Ground pin 43 (⇒ *Figure 37-1-*) → main wire harness above wheel housing liner (at the left ⇒ *Figure 37-2-*) → along main wire harness → bore for sleeve on vehicle floor (left)

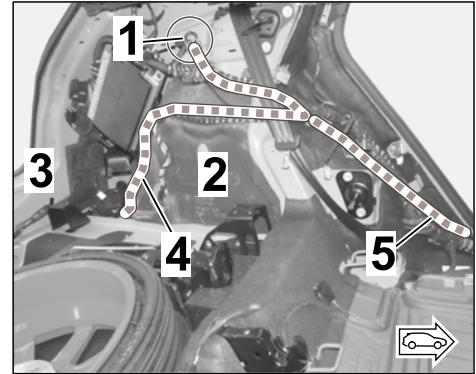

Figure 37

3.3 Guide connector (4-pin) through the bore to the underside of the vehicle and fit sleeve into the bore (⇒ *Figure 38*).

- 1 – Sleeve
- 2 – Branch for exhaust flap (left)
- 3 – Tie-wrap

3.4 Route branch for connection point to the fuse box (E-box) in the cowl panel as follows:

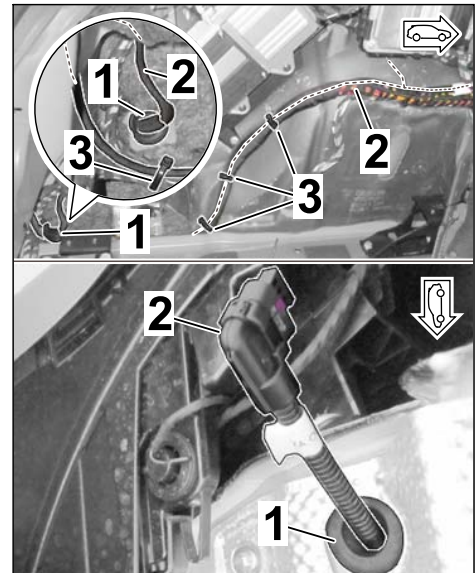

Figure 38

3.4.1 **ONLY** for left-hand drive vehicles (⇒ *Figure 39*):

Arrow – Ground pin 43

- Ground pin 43 → door sill at C-pillar (left) → door sill at B-pillar (left) → A-pillar (left) → opening on bulkhead (left) → fuse box (E-box) in cowl panel (left)

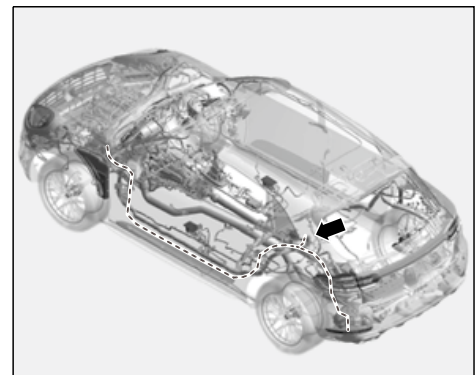

Figure 39

3.5 Connect branch for connection point

3.5.1 Remove and release connector (17-pin, red) from fuse/relay carrier (E-box, connection point X371.1A1) (⇒ Figure 42).

- 1 – Connector (17-pin, red)
- 2 – Fuse/relay carrier (E-box)
- 3 – Secondary lock

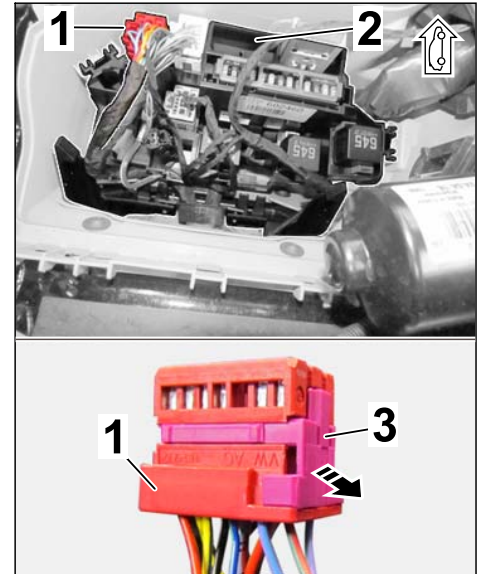

Figure 42

3.5.2 Change pin assignment of RD/GN, BU/VT and VT/BU lines in the connector (17-pin, red) and insert as follows:

- 1 – Connector (17-pin, red)
- 2 – Plug socket (2-pin)
- 3 – Pin connector socket (2-pin)
- 4 – Line VT/BU; 0.5² (wire harness for connection point/exhaust flap)
- 5 – Line BU/VT; 0.5² (wire harness for connection point/exhaust flap)
- 6 – Line RD/GN; 0.5² (on vehicle side)

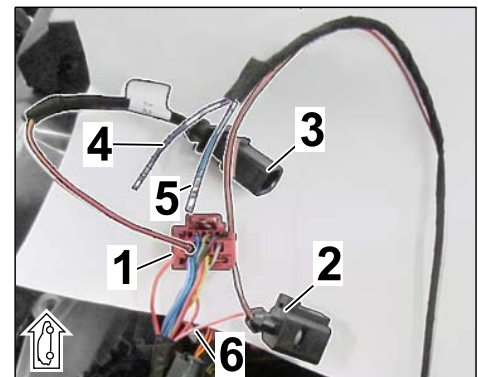

Figure 43

Function/line:	Connector (17-pin, red)
Terminal 87A (supply) Exhaust flap (right) = RD/GN; 0.5 ²	Unpin socket from chamber 17 ⇒ insert into chamber 2 of plug socket (2-pin ⇒ Figure 43-2-)
Terminal 87A (supply) Exhaust flap (new) = RD/GN; 0.5 ²	Socket from pin connector socket (2-pin, black) ⇒ insert into chamber 17 of connector (17-pin, red ⇒ Figure 43-1-)

Control Exhaust flap (new) = VT/BU; 0.5 ²	Socket from wire harness for connection point/exhaust flap ⇒ insert into chamber 6 of connector (17-pin, red ⇒ <i>Figure 43-1-</i>)
Status Exhaust flap (new) = BU/VT; 0.5 ²	Socket from wire harness for connection point/exhaust flap ⇒ insert into chamber 9 of connector (17-pin, red ⇒ <i>Figure 43-1-</i>)

3.5.3 Connect plug connection (2-pin) (⇒ *Figure 43-2 and 3-*).

3.6 Secure plug connections (CAN lines/terminal 87A) to existing lines/components in the fuse box (E-box) in the cowl panel with tie-wraps without tension and so that no chafing occurs (⇒ *Figure 44*).

- 1 – Plug connection (terminal 87A)
- 2 – Plug connection (CAN lines)
- 3 – Tie-wrap

3.7 Secure routed wire harness for connection point/exhaust flap in the vehicle to existing lines/components with tie-wraps without tension and so that no chafing occurs.

Secure extra length of line if necessary.

4 Convert front button module

4.1 Remove switch console (⇒ *Workshop Manual '962719 Removing and installing switch console*).

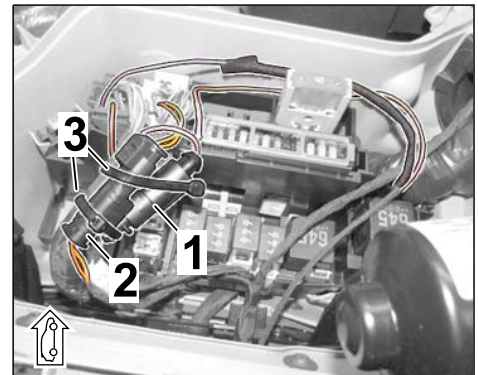

Figure 44

4.2 Replace button module at the right (⇒ *Figure 45*)

- 1 – Switch console
- 2 – Electric plug connection
- 3 – Button module (right)
- 4 – New button module (right)

4.2.1 Disconnect electrical plug connection.

4.2.2 Remove screws (⇒ *Figure 45 -Arrows-*).

4.2.3 Replace installed button module (⇒ *Figure 45-3-*) with a new button module with "Sport exhaust system" button (⇒ *Figure 45-4-*).

4.2.4 Tighten screws and connect electric plug connection.

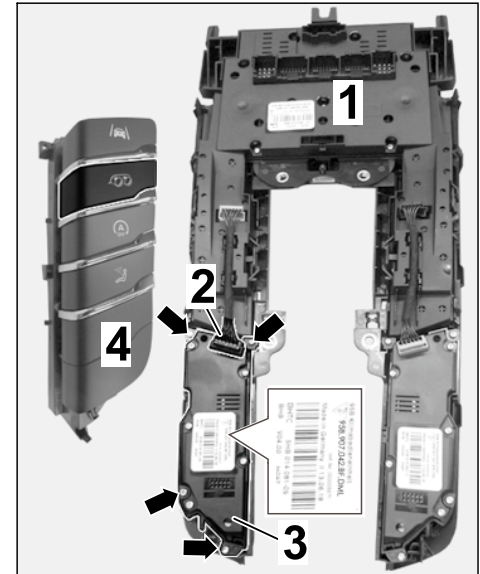

Figure 45

4.3 Install switch console (⇒ *Workshop Manual '962719 Removing and installing switch console*).

5 Concluding work for vehicle interior/engine compartment

5.1 Assemble luggage compartment/C-pillar area

5.1.1 Install rear inner door sill trim (on driver's side) (⇒ *Workshop Manual '680519 Removing and installing rear inner door sill trim*).

5.1.2 **ONLY** for vehicles with spare wheel (space-saving – 1G1/1G4):
Remove compressor tool kit.

5.1.3 Install side trim panel for luggage compartment (loadspace cover) (⇒ *Workshop Manual '700619 Removing and installing side trim panel for luggage compartment (luggage compartment cover)*).

5.1.4 Install side trim panel for rear luggage compartment (at the left and right) (⇒ *Workshop Manual '700319 Removing and installing side trim panel for rear luggage compartment*).

5.2 Assemble B-pillar area (on driver's side)

5.2.1 Install lower part of B-pillar trim panel (on driver's side) (⇒ *Workshop Manual '70671903 Removing and installing lower part of B-pillar trim panel*).

5.2.2 Install upper part of B-pillar trim panel (on driver's side) (⇒ *Workshop Manual '706719 Removing and installing upper part of B-pillar trim panel*).

5.2.3 Install rear seat (⇒ *Workshop Manual '724819 Removing and installing rear seat*).

- 5.2.4 Secure/install rear backrest (⇒ *Workshop Manual '724719 Removing and installing rear backrest'*).
- Secure belt fitting on 1/3-split folding seat backrest using a new screw.
- Tightening torque 50 Nm (37 ftlb.)**
- 5.2.5 Place items in luggage compartment and fit luggage compartment cover.
- 5.3 Assemble A-pillar area (on driver's side)
- 5.3.1 Install front inner door sill trim (⇒ *Workshop Manual '680519 Removing and installing front inner door sill trim'*).
- 5.3.2 Install trim panel under dashboard (⇒ *Workshop Manual '701919 Removing and installing trim panel under dashboard on driver's side'*).
- 5.3.3 Install dashboard moulding/trim panel (at the right) (⇒ *Workshop Manual '70581902 Removing and installing dashboard moulding on driver's side (right)'*).
- 5.3.4 Install air vent (on instrument cluster) and air vent unit (underneath the PCM).
- 5.3.5 Install dashboard trim panel (⇒ *Workshop Manual '701619 Removing and installing dashboard trim panel'*).
- 5.4 Assemble plenum panel area
- 5.4.1 Install foam pads on bulkhead (⇒ *Figure 46 -2-*).
- 1 – Fuse box (E-box) in cowl panel
 - 2 – Foam pads on bulkhead
- 5.4.2 Install cover on fuse box (E-box) in cowl panel (⇒ *Figure 46, ⇒ Workshop Manual '978409 Loosening and securing fuse box'*).
- 5.4.3 Install cowl panel cover (⇒ *Workshop Manual '508719 Removing and installing cowl panel cover'*).
- 5.4.4 Install wiper arms (⇒ *Workshop Manual '922519 Removing and installing wiper arm'*).
- 5.4.5 Move front lid out of service position (⇒ *Workshop Manual '552213 Securing front lid (service position)'*).
- 6 Install new exhaust system (see also ⇒ *Workshop Manual '260119 Removing and installing exhaust system (V6 Turbo)'*)
- 6.1 Position and secure heat insulation in the rear muffler area (at the left).

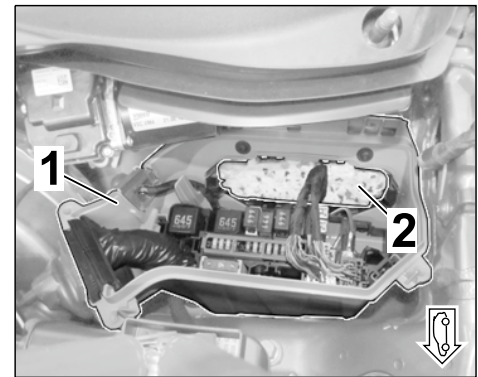

Figure 46

Tightening torque 2 Nm (1.5 ftlb.)

6.2 Install new exhaust pipe (⇒ *Figure 47*).

- 1 – Clamping sleeve, Ø 65 x 88
- 2 – Exhaust pipe

6.2.1 Fit clamping sleeve (Ø 65 x 88) on catalytic converter exhaust pipe (at the left/right).

6.2.2 Secure new exhaust pipe on **VAS 6931 - engine and gearbox jack** with belts and move it into installation position.

6.2.3 Fit holder at the left/right hand-tight.

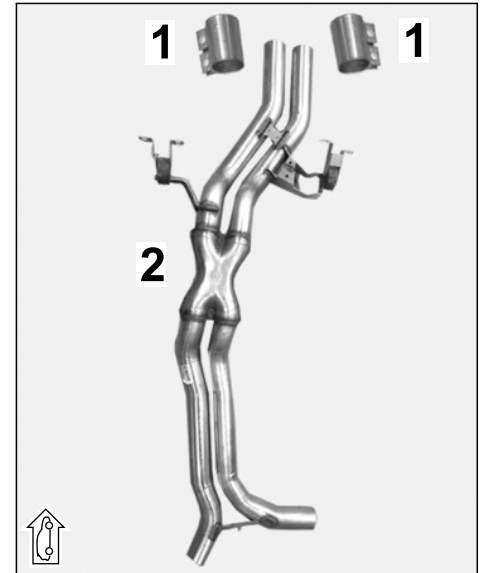

Figure 47

6.3 Install new rear mufflers (⇒ *Figure 48 (4-cylinder)*).

- 1 – Center muffler (exhaust pipe on V6 engine)
- 2 – Clamping sleeve, Ø 65 x 88
- 3 – Rear muffler (left)
- 4 – Rear muffler (right)
- 5 – Sport tailpipes (left)
- 6 – Sport tailpipes (right)

6.3.1 Fit new clamping sleeves (Ø 65 x 88, 2 x) on exhaust pipe on center muffler.

6.3.2 Pre-fit new rear muffler (left/right) hand-tight (⇒ *Workshop Manual '263355 Replacing rear silencer*)

6.4 Install new sport tailpipes.

6.4.1 Carefully guide sports tailpipes (left/right) through the cut-out on the rear apron and as far as they will go onto the rear muffler connection piece.

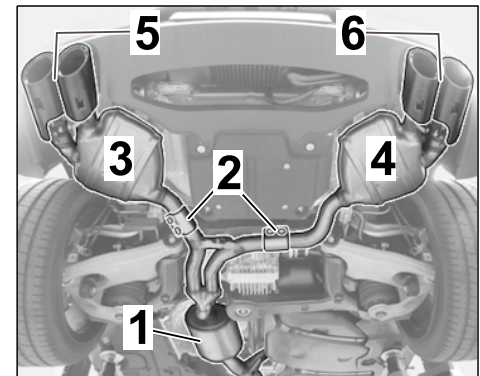

Figure 48 (4-cylinder)



Information

The tailpipes are adjusted in X direction using the slots in the tailpipe.

6.4.2 Check projection of tailpipe cover on sport tailpipes (left/right) and cover on exhaust system (rear apron) and adjust evenly.

Align the complete exhaust system if necessary.

6.4.3 Tighten countersunk screw (M6 x 12; on underside of cover on sports tailpipe).

Tightening torque 8 Nm (6 ftlb.) +/-1 Nm (+/-0.5 ftlb.)

6.5 Tighten all threaded connections on the exhaust system fully to the specified torque (⇒ *Workshop Manual '2X00IN Technical values (V6 Turbo)*).

6.6 Install tunnel cover on –center– underbody (⇒ *Workshop Manual '519319 Removing and installing cover for centre underbody*).

Coding:

NOTICE

Voltage drop

- Risk of irreparable damage to control unit
 - Risk of damage to control unit
 - Fault entries in the control unit
 - Coding in the control unit is aborted
 - Malfunctions in control unit, even during programming
- ⇒ Switch off the ignition and remove the ignition key before disconnecting the control unit.
- ⇒ Ensure that the power supply is not interrupted during programming.
- ⇒ Connect a battery charger with a current rating of at least Nominal value 90 A to the vehicle battery.

7 Entering the sport exhaust system (OP8 or OP9) in the vehicle data

7.1 Preparatory work – Coding

NOTICE

Control unit programming will be aborted if the Internet connection is unstable.

- An unstable Internet connection can interrupt communication between PIWIS Tester III and the vehicle communication module (VCI). As a result, control unit programming may be aborted.
- ⇒ During control unit programming, always connect PIWIS Tester III to the vehicle communication module (VCI) via the USB cable.

7.1.1 **9900 - PIWIS Tester 3** must be connected to the vehicle and switched on.

7.1.2 Switch on ignition **AND** hazard warning lights on the vehicle.



Information

The **9900 - PIWIS Tester III** instructions take precedence since the description may be different with later Tester releases.

The procedure described here has been structured in general terms; different text or additions may appear on the **9900 - PIWIS Tester III**.

- 7.1.3 Select the "Diagnostics" menu item on the PIWIS Tester.
- 7.1.4 If **9900 - PIWIS Tester 3** is connected correctly, a connection to the vehicle will be established: "Macan model line" is detected.
- 7.2 Enter the new vehicle equipment in the vehicle data
 - 7.2.1 Press **•F7** in the control unit overview to switch to the "Additional menu". Press **•F12** to confirm the question "Create Vehicle Analysis Log (VAL)?".
 - 7.2.2 Select the "Management of vehicle order" function. Continue pressing **•F12** until "PR numbers" is displayed in the Value group column.
 - 7.2.3 Look for the option "INTERIOR SOUND MEASURES (SILENCERS)" in the "Family" column.

Select the option "2HB – INTERIOR SOUND MEASURES (SHAKER)" from the drop-down menu in the "Value" column.
 - 7.2.4 Look for the option "EXHAUST TAILPIPE" in the "Family" column.

Select the required option "OP8 – SPORT EXHAUST SYSTEM – STAINLESS-STEEL TAILPIPES" or "OP9 – SPORT EXHAUST SYSTEM – BLACK TAILPIPES" from the drop-down menu in the "Value" column.
 - 7.2.5 Press **•F12** to continue. A table containing coding values (old and new value) is displayed in the overview.
 - 7.2.6 Press **•F8** to continue. Data is then written/stored.
 - 7.2.7 Wait until the message "Creation of vehicle data has been completed." appears. Press **•F12** to go to Report management.
 - 7.2.8 Press **•F10** to open the log. Check that the selected vehicle equipment has been entered and close the log.
- 7.3 Code/program the new vehicle equipment.
 - 7.3.1 Select **ALL** control units (**•CTRL+A**) in the control unit overview and switch to the "Coding/programming" column.
 - 7.3.2 Select the coding mode "Automatic coding". Press **•F12** to continue.
 - 7.3.3 Once "Automatic coding" is complete, the message "Coding was completed successfully. Press **•F12** to continue." appears in the header.

Switch to the control unit overview.

- 7.4 Read out the fault memory of all systems, work through any existing faults and erase the fault memory (⇒ *Workshop Manual '0X03IN Diagnostic maintenance: Diagnostic system and maintenance inter...*).
- 7.5 Switch off ignition and disconnect **9900 - PIWIS Tester 3**.
- 7.6 Perform "Sport exhaust system" function test
 - 7.6.1 Perform a test drive.
 - 7.6.2 Switch sport exhaust system on and off using the "Twin tailpipe" button (switch panel on centre console) and/or switch "Sport Plus mode" (vehicles with "Sport Chrono Package") on and off.
 - 7.6.3 You will hear a change in the noise level between the individual driving modes.

26 01 31 01: –Sport exhaust system (1 x) retrofitted–

Labor time: **566 TU**

- Includes: Installing engine noise pulse sender and control unit;
Routing and connecting electric wire harness;
Installing new exhaust pipe and replacing rear mufflers (left/right);
Installing and aligning new sport tailpipes (4 x);
Coding sport exhaust system;
Reading out fault memory and correcting and erasing faults.
- Without: Test drive

Important Notice: Technical Bulletins issued by Porsche Cars North America, Inc. are intended only for use by professional automotive technicians who have attended Porsche service training courses. They are written to inform those technicians of conditions that may occur on some Porsche vehicles, or to provide information that could assist in the proper servicing of a vehicle. Porsche special tools may be necessary in order to perform certain operations identified in these bulletins. Use of tools and procedures other than those Porsche recommends in these bulletins may be detrimental to the safe operation of your vehicle, and may endanger the people working on it. Properly trained Porsche technicians have the equipment, tools, safety instructions, and know-how to do the job properly and safely. Part numbers listed in these bulletins are for reference only. The work procedures updated electronically in the Porsche PIWIS diagnostic and testing device take precedence and, in the event of a discrepancy, the work procedures in the PIWIS Tester are the ones that must be followed.

© 2019 Porsche Cars North America, Inc.